

www.dhawanlearning.com

EASY From JEE

Easy 40% from 2017

Guidance by
Ex IIT, 28 Yrs EXP

JEE easy

The following observations were taken for determining surface tension T of water by capillary method : Diameter of capillary, $D = 1.25 \times 10^{-2}$ m rise of water, $h = 1.45 \times 10^{-2}$ m Using $g = 9.80 \text{ m/s}^2$ and the

Simplified relation $T = \frac{r h g}{2} \times 10^3 \text{ N/m}$

the possible error in surface tension is closest to :

- (1) 2.4% (2) 10% (3) 0.15% (4) 1.5% [JEE 2017]

JEE easy

An electron beam is accelerated by a potential difference V to hit a metallic target to produce X-rays. It produces continuous as well as characteristic X-rays. If λ_{\min} is the smallest possible wavelength of X-ray in the spectrum, the variation of $\log \lambda_{\min}$ with $\log V$ is correctly represented in :

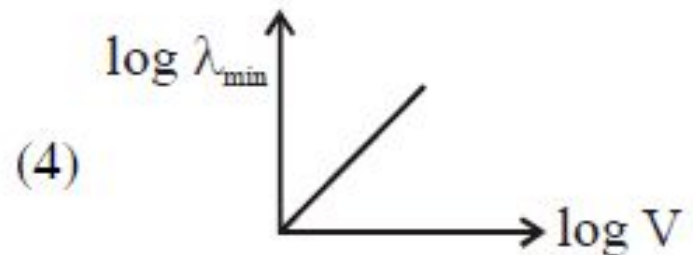
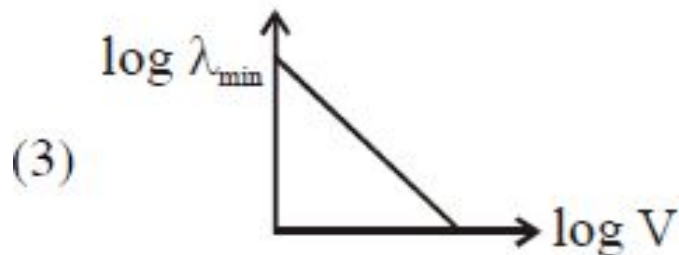
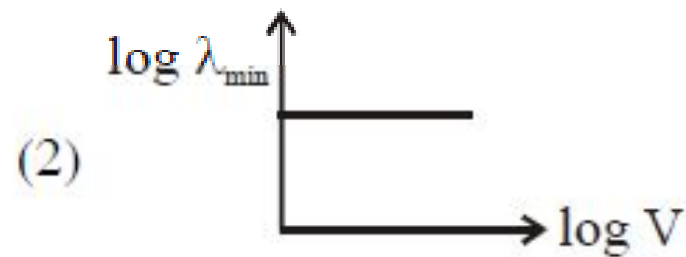
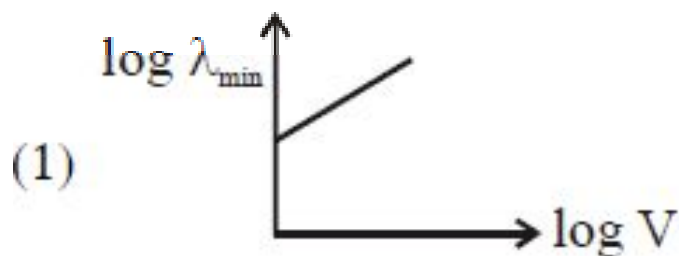

JEE easy

JEE easy

A slender uniform rod of mass M and length L is pivoted at one end so that it can rotate in a vertical plane (see figure). There is negligible friction at the pivot. The free end is held vertically above the pivot and then released. The angular acceleration of the rod when it makes an angle θ with the vertical is

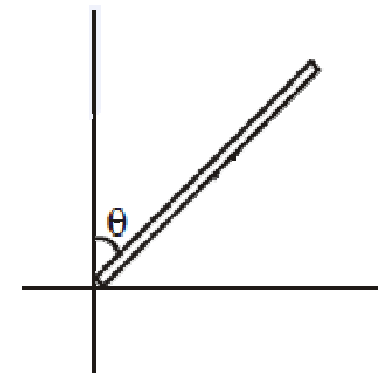

- (1) $\frac{3g}{2L} \cos \theta$ (2) $\frac{2g}{3L} \cos \theta$ (3) $\frac{3g}{2L} \sin \theta$ (4) $\frac{2g}{3L} \sin \theta$

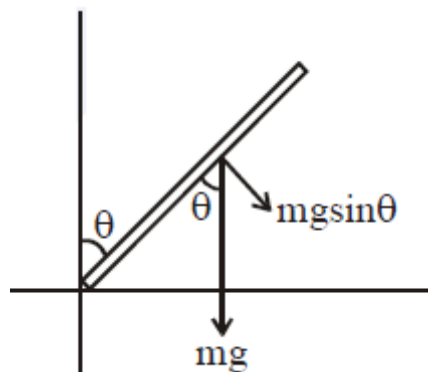

$$\text{Toque} = mg \sin \theta \cdot \frac{L}{2} = I\alpha = \frac{mL^2}{3} \alpha \Rightarrow \alpha = \frac{3g}{2L} \sin \theta$$

JEE easy

A body is thrown vertically upwards. Which one of the following graphs correctly represent the velocity vs time?

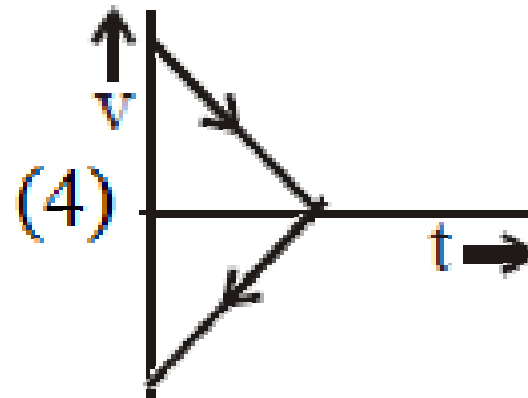
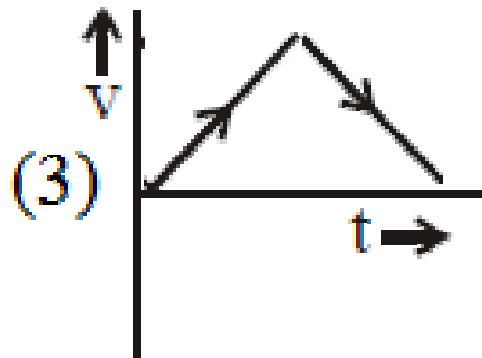
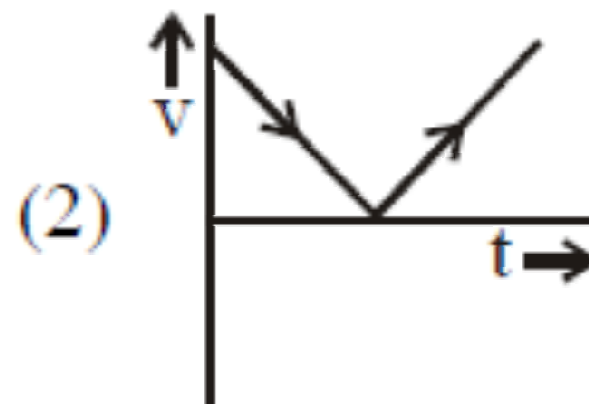
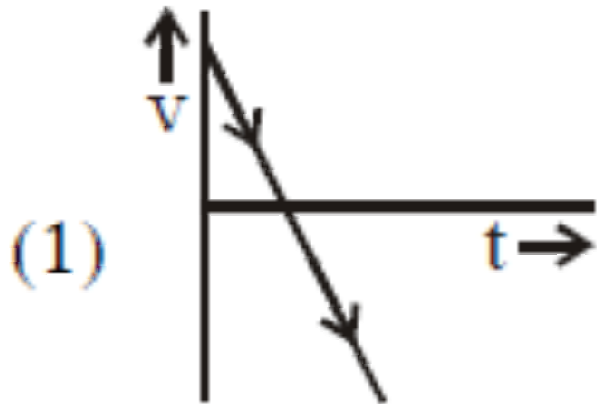

$v = u + at$; u is positive, a is negative, At highest point v is zero

JEE easy

A capacitance of $2 \mu\text{F}$ is required in an electrical circuit across a potential difference of 1.0 kV . A large number of $1 \mu\text{F}$ capacitors are available which can withstand a potential difference of not more than 300 V . the minimum number of capacitors required to achieve this is :

(1) 32

(2) 2

(3) 16

(4) 24

EXACT NCERT 2.23

JEE easy

In the given circuit diagram when the current reaches steady state in the circuit, the charge on the capacitor of capacitance C will be :

(1) $\frac{CEr_2}{r + r_2}$

(2) $\frac{CEr_1}{r + r_1}$

(3) CE

(4) $\frac{CEr_1}{r + r_2}$

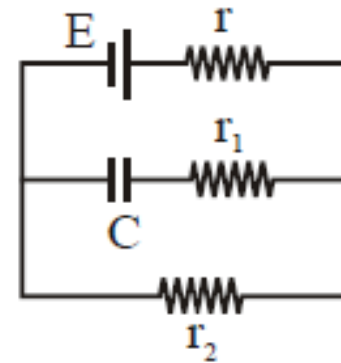

JEE easy

In a common emitter amplifier circuit using an n-p-n transistor, the phase difference between the input and the output voltages will be :

- (1) 180° (2) 45° (3) 90° (4) 135°

COMMON EMITER CONFIGURATION 180

JEE easy

Which of the following statements is false ?

- (1) Kirchhoff's second law represent energy conservation.
- (2) Wheatstone bridge is the most sensitive when all the four resistances are of the same order magnitude.
- (3) In a balanced Wheatstone bridge the cell and the galvanometer are exchanged, the null point is disturbed.
- (4) A rheostat can be used as a potential divider.

JEE easy

A particle is executing simple harmonic motion with a time period T . At time $t=0$, it is at its position of equilibrium. The kinetic energy - time graph of the particle will look like :

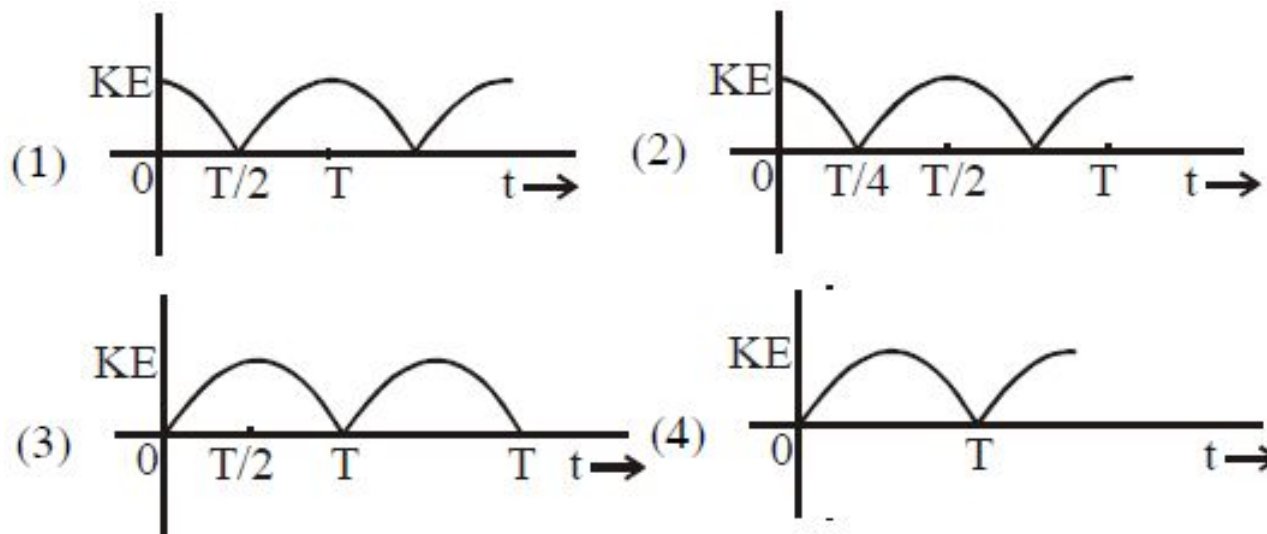

JEE easy

When a current of 5 mA is passed through a galvanometer having a coil of resistance 15Ω , it shows full scale deflection. The value of the resistance to be put in series with the galvanometer to convert it into a voltmeter of range 0–10 V is :

- (1) $4.005 \times 10^3 \Omega$ (2) $1.985 \times 10^3 \Omega$ (3) $2.045 \times 10^3 \Omega$ (4) $2.535 \times 10^3 \Omega$

JEE easy

The variation of acceleration due to gravity g with distance d from centre of the earth is best represented by ($R = \text{Earth's radius}$) :

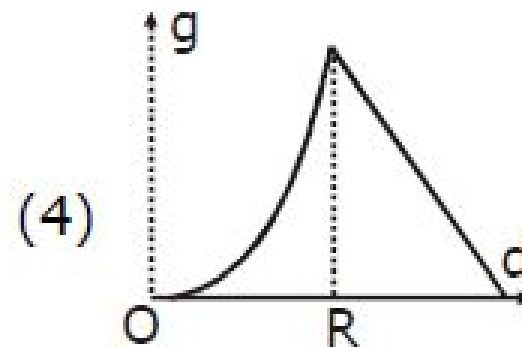
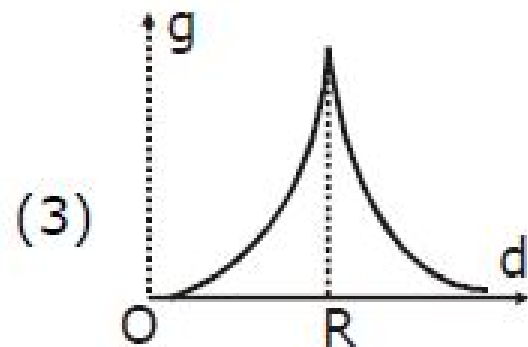
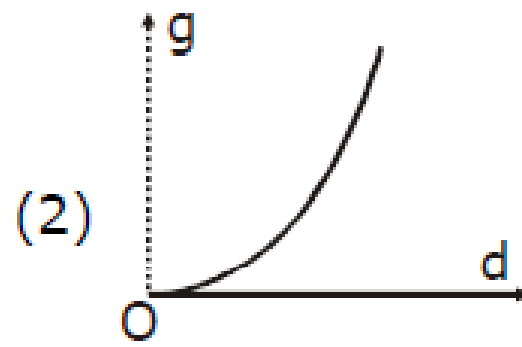
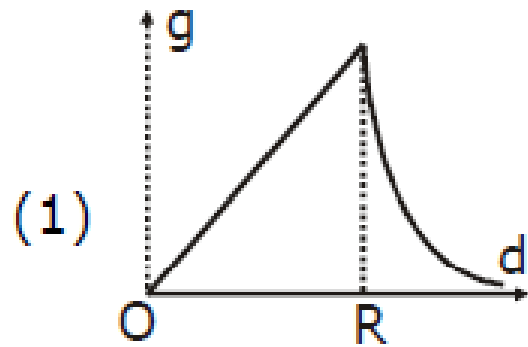

JEE easy

A diverging lens with magnitude of focal length 25 cm is placed at a distance of 15 cm from a converging lens of magnitude of focal length 20 cm. A beam of parallel light falls on the diverging lens.,
The final image formed is :

- (1) real and at a distance of 6 cm from the convergent lens.
- (2) real and at a distance of 40 cm from convergent lens.
- (3) virtual and at a distance of 40 cm from convergent lens.
- (4) real and at distance of 40 cm from the divergent lens.